

# JENN-AIR® 15" (38.1 CM) DOWNDRAFT VENT

---

## Use and Care Guide

For questions about features, operation/performance, parts, accessories, or service in the U.S.A., call: **1-800-JENNAIR (1-800-536-6247)** or visit our website at **www.jennair.com**.

In Canada, call: **1-800-JENNAIR (1-800-536-6247)** or visit our website at **www.jennair.ca**.

---

Table of Contents.....	2
------------------------	---

---

**IMPORTANT: READ AND SAVE THESE INSTRUCTIONS.  
FOR RESIDENTIAL USE ONLY.**

**JENN-AIR®**

W11170798A

# TABLE OF CONTENTS

<b>VENT SAFETY</b> .....	<b>2</b>
<b>VENT USE</b> .....	<b>4</b>
LED Illumination .....	4
<b>VENT CARE</b> .....	<b>5</b>
General Cleaning.....	5
<b>TROUBLESHOOTING</b> .....	<b>6</b>
<b>ASSISTANCE OR SERVICE</b> .....	<b>7</b>
In the U.S.A. ....	7
In Canada .....	7
Accessories .....	7
<b>WARRANTY</b> .....	<b>8</b>

## VENT SAFETY

### Your safety and the safety of others are very important.

We have provided many important safety messages in this manual and on your appliance. Always read and obey all safety messages.



This is the safety alert symbol.

This symbol alerts you to potential hazards that can kill or hurt you and others.

All safety messages will follow the safety alert symbol and either the word “DANGER” or “WARNING.”

These words mean:

**! DANGER**

**You can be killed or seriously injured if you don't immediately follow instructions.**

**! WARNING**

**You can be killed or seriously injured if you don't follow instructions.**

All safety messages will tell you what the potential hazard is, tell you how to reduce the chance of injury, and tell you what can happen if the instructions are not followed.

State of California Proposition 65 Warnings:

**WARNING:** This product contains one or more chemicals known to the State of California to cause cancer.

**WARNING:** This product contains one or more chemicals known to the State of California to cause birth defects or other reproductive harm.

# IMPORTANT SAFETY INSTRUCTIONS

**WARNING:** TO REDUCE THE RISK OF FIRE, ELECTRIC SHOCK, OR INJURY TO PERSONS, OBSERVE THE FOLLOWING:

- Use this unit only in the manner intended by the manufacturer. If you have questions, contact the manufacturer.
- Before servicing or cleaning the unit, switch power off at service panel and lock the service disconnecting means to prevent power from being switched on accidentally. When the service disconnecting means cannot be locked, securely fasten a prominent warning device, such as a tag, to the service panel.
- Installation work and electrical wiring must be done by qualified person(s) in accordance with all applicable codes and standards, including fire-rated construction.
- Do not operate any fan with a damaged cord or plug. Discard fan or return to an authorized service facility for examination and/or repair.
- Sufficient air is needed for proper combustion and exhausting of gases through the flue (chimney) of fuel burning equipment to prevent backdrafting. Follow the heating equipment manufacturer's guideline and safety standards such as those published by the National Fire Protection Association (NFPA), the American Society for Heating, Refrigeration and Air Conditioning Engineers (ASHRAE), and the local code authorities.
- When cutting or drilling into wall or ceiling, do not damage electrical wiring and other hidden utilities.
- Ducted fans must always be vented outdoors.

**CAUTION:** For general ventilating use only. Do not use to exhaust hazardous or explosive materials and vapors.

**CAUTION:** To reduce risk of fire and to properly exhaust air, be sure to duct air outside - do not vent exhaust air into spaces within walls or ceilings, attics or into crawl spaces, or garages.

**WARNING:** TO REDUCE THE RISK OF FIRE, USE ONLY METAL DUCTWORK.

**WARNING:** TO REDUCE THE RISK OF A RANGE TOP GREASE FIRE:

- Never leave surface units unattended at high settings. Boilovers cause smoking and greasy spillovers that may ignite. Heat oils slowly on low or medium settings.
- Always turn hood ON when cooking at high heat or when flambeing food (i.e. Crepes Suzette, Cherries Jubilee, Peppercorn Beef Flambe).
- Clean ventilating fans frequently. Grease should not be allowed to accumulate on fan or filter.
- Use proper pan size. Always use cookware appropriate for the size of the surface element.

**WARNING:** TO REDUCE THE RISK OF INJURY TO PERSONS IN THE EVENT OF A RANGE TOP GREASE FIRE, OBSERVE THE FOLLOWING:<sup>a</sup>

- SMOTHER FLAMES with a close fitting lid, cookie sheet, or metal tray, then turn off the burner. BE CAREFUL TO PREVENT BURNS. If the flames do not go out immediately, EVACUATE AND CALL THE FIRE DEPARTMENT.
- NEVER PICK UP A FLAMING PAN - you may be burned.
- DO NOT USE WATER, including wet dishcloths or towels - a violent steam explosion will result.
- Use an extinguisher ONLY if:
  - You know you have a class ABC extinguisher, and you already know how to operate it.
  - The fire is small and contained in the area where it started.
  - The fire department is being called.
  - You can fight the fire with your back to an exit.

<sup>a</sup>Based on "Kitchen Fire Safety Tips" published by NFPA.

- **WARNING:** To reduce the risk of fire or electrical shock, do not use this fan with any solid-state speed control device.

## READ AND SAVE THESE INSTRUCTIONS

# VENT USE

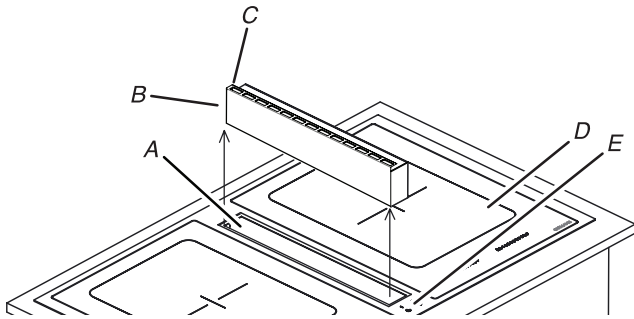

- A. Vent door
- B. Vent filter
- C. Filter handle
- D. Cooktop
- E. Vent controls

The vent removes cooking vapors, odors, and smoke from the cooktop area. The vent consists of a vent filter, vent ducting, and a vent fan.

- For best results, the vent should be turned ON before cooking is started.
- A higher heat setting than normal may be needed when the vent is operating.
- The handle of the vent filter should be on the left-hand side of the filter opening when facing the front of the vent. See the previous illustration.

**IMPORTANT:** Only operate the vent with the vent filter properly installed. Clean the filter regularly. Non-vented (recirculation) use requires the installation of the Recirculation Kit Accessory.

## To Use:

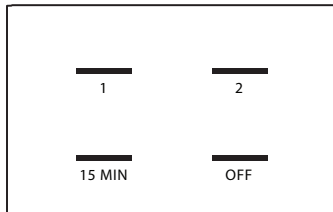

## To Turn On Vent:

1. Push down on the right side of the vent door. A magnet will keep the vent door open.

**NOTE:** The vent will not operate if the vent door is closed.

2. Tap the bar (■) above the "1" keypad for low speed. Tap the bar (■) above the "2" keypad for high speed.

**NOTE:** The vent has a Timer On mode. Tap the bar (■) above the "15 MIN" keypad. The vent will only run on low speed and will automatically turn off after 15 minutes while in the Timer On mode.

## To Turn Off Vent:

1. Tap the bar (■) above the "OFF" keypad.

## LED Illumination

There is an LED light below the vent door that comes on automatically when the vent door is opened. To turn the LED light off when the door is open, press the LED light switch.

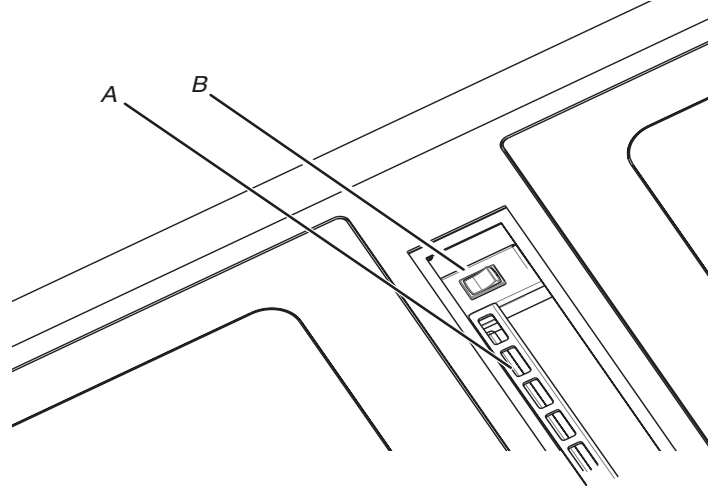

- A. LED light
- B. LED light switch

# VENT CARE

## General Cleaning

**IMPORTANT:** Before cleaning, make sure all controls are OFF and the adjacent cooktops are cool. Always follow label instructions on cleaning products. As extra reference, see the cleaning instructions for the cooktop surface.

Soap, water, and a soft, damp cloth or sponge are suggested first unless otherwise noted.

### Vent

Do not use steel wool, abrasive powder cleansers, chlorine bleach, rust remover, or ammonia because damage may occur.

**NOTE:** Wipe in the direction of the brush lines to avoid damage.

#### Light to moderate soil

- Can be cleaned with damp paper towels or sponge. Light stains should be addressed with cleaner and cleaning pad.

#### Heavy soil, dark streaks, specks, and discoloration

- Clean with affresh® Cooktop Cleaner or nonabrasive cleaner and Cooktop Cleaning Pads.

### Vent Filter

The grease filter for the vent should be cleaned regularly. Grease build-up decreases the vent's performance.

#### To Clean Metal Vent Filter:

1. Open the vent filter door and remove the vent filter.
2. Clean the filter using warm water with a mild dishwashing soap.

Allow the filter to dry before installing in vent.

**NOTE:** The metal grease filter can be cleaned by handwashing or in a dishwasher with a mild dishwashing soap at a low temperature. Do not use aggressive or multi-phase cleaning agents or clean at temperatures above 130°F (54°C)

### Drip Pan

If a spill occurs on the cooktop and into the vent area, turn off the cooktop and vent as soon as possible. Let the adjacent cooking surfaces cool, remove the vent filter, and clean as necessary. Wipe the vent area clean. The drip pan should always be removed, emptied, and cleaned anytime there is a spill or boilover. The drip pan should be removed, emptied, and cleaned often to avoid drip pan overflow and possible odors.

#### Drip pan removal:

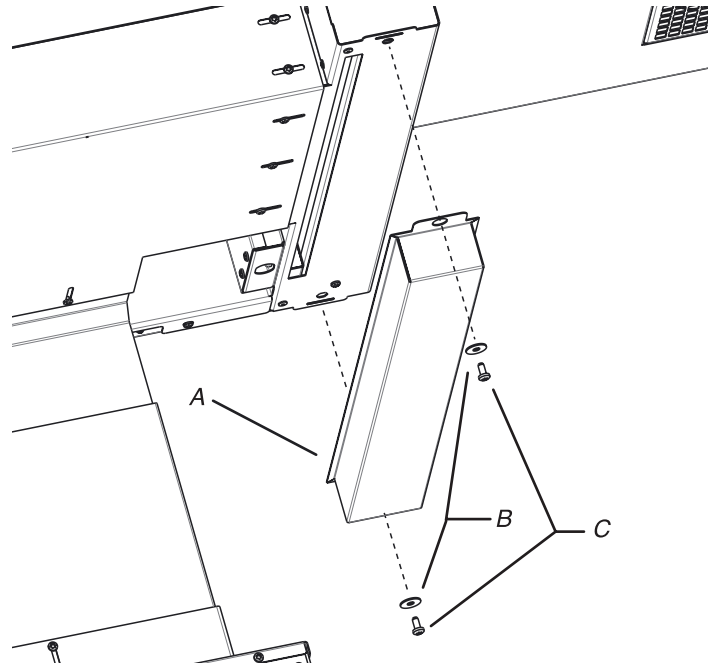

- A. Drip pan
- B. Flat washers (2)
- C. Screws (2)

1. Remove screws to remove pan.

**NOTE:** Loosen rear screw (do not remove) and remove front screw to remove pan by sliding forward. This will make for easier pan installation.

2. Remove the drip pan and dispose of the liquids and grease buildup inside. Clean the drip pan inside and out with warm soapy water, and then rinse and dry.

#### Drip Pan Installation:

**NOTE:** The drip pan should always be attached to the vent except when it is removed for cleaning.

1. Replace pan by inserting rear tab in screw and fastening front of pan with screw. Tighten both screws.

## Recirculation Filters

If the vent is set up for recirculation, the Recirculation Kit includes 2 charcoal filters. The charcoal filters should be replaced every 3 years, or more often if needed due to the intensity of cooking. The charcoal filters are located behind the recirculation cover.

**NOTE:** These charcoal filters cannot be washed or recharged.

### To Remove the Charcoal Filters:

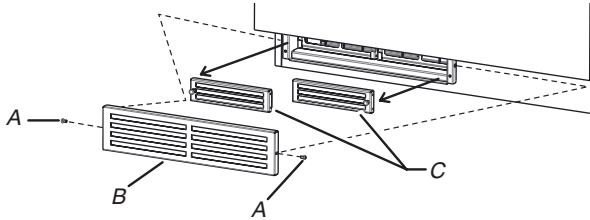

A. Screws (2)  
B. Recirculation system cover  
C. Charcoal filter (2)

1. Using a  $\frac{3}{16}$ " (4.8 mm) hex driver, remove the 2 screws from the ends of the recirculation system cover. Remove the cover and set aside.
2. Remove the charcoal filters by pulling out on the filter handles.
3. Replace with new charcoal filters. To order a replacement charcoal filter kit, see the "Assistance or Service" section.
4. Replace the recirculation system cover and secure with the 2 screws. Tighten the screws with the hex driver.

## TROUBLESHOOTING

First try the solutions suggested here. If you need further assistance or more recommendations that may help you avoid a service call, refer to the warranty page in this manual, or visit <https://jennair.custhelp.com>. In Canada, visit <http://www.jennair.ca>.

Contact us by mail with any questions or concerns at the address below:

In the U.S.A.:

Jenn-Air Brand Home Appliances  
Customer eXperience Center  
553 Benson Road  
Benton Harbor, MI 49022-2692

In Canada:

Jenn-Air Brand Home Appliances  
Customer eXperience Centre  
200 - 6750 Century Ave.  
Mississauga, Ontario L5N 0B7

Please include a daytime phone number in your correspondence.

**⚠ WARNING**

**Electrical Shock Hazard**

**Plug into a grounded 3 prong outlet.**

**Do not remove ground prong.**

**Do not use an adapter.**

**Do not use an extension cord.**

**Failure to follow these instructions can result in death, fire, or electrical shock.**

Problem	Possible Causes and/or Solutions
Nothing will operate	<p><b>Is the unit plugged into a grounded 3 prong outlet?</b> Call for service. See the "Warranty" section for contact information.</p> <p><b>Has a household fuse blown or has a circuit breaker tripped?</b> Replace the fuse or reset the circuit breaker. If the problem continues, call for service. See the "Warranty" section for contact information.</p> <p><b>Is the vent door closed?</b> If it is closed, push down on the right side of the vent door. A magnet will keep the vent door open. If the vent door will not stay open, the vent may not be connected to the receptacle outlet in the electronics connection box. Call for service. See the "Warranty" section for contact information.</p>
Very little air movement	<p><b>Is the filter installed backwards?</b> The filter handle should be on the left-hand side of the filter opening. See the "Vent Use" section.</p> <p><b>Is there an obstruction in the vent system or vent damper?</b> Check the vent system for obstructions.</p> <p><b>Is the vent damper obstructed or not working correctly?</b> Check the vent damper for obstructions or binding.</p>

---

# ASSISTANCE OR SERVICE

---

## If you need service:

Please refer to the warranty page in this manual.

## If you need replacement parts:

If you need to order replacement parts, we recommend that you use only factory specified parts. These factory specified parts will fit right and work right because they are made with the same precision used to build every new Jenn-Air® appliance.

To locate factory specified parts in your area, call us or your nearest Jenn-Air designated service center.

---

## In the U.S.A.

Call the Jenn-Air Customer eXperience Center toll-free: **1-800-JENNAIR (1-800-536-6247)** or visit our website at **www.jennair.com**.

### Our consultants provide assistance with:

- Scheduling of service. Jenn-Air® appliances designated service technicians are trained to fulfill the product warranty and provide after-warranty service anywhere in the United States.
- Features and specifications on our full line of appliances.
- Referrals to local Jenn-Air® appliance dealers.
- Installation information.
- Use and maintenance procedures.
- Accessory and repair parts sales.
- Specialized customer assistance (Spanish speaking, hearing impaired, limited vision, etc.).

### For further assistance:

If you need further assistance, you can write to Jenn-Air with any questions or concerns at:

Jenn-Air Brand Home Appliances  
Customer eXperience Center  
553 Benson Road  
Benton Harbor, MI 49022-2692

Please include a daytime phone number in your correspondence.

## In Canada

Call the Jenn-Air Canada Customer eXperience Centre toll-free: **1-800-JENNAIR (1-800-536-6247)** or visit our website at **www.jennair.ca**.

### Our consultants provide assistance with:

- Scheduling of service. Jenn-Air® appliances designated service technicians are trained to fulfill the product warranty and provide after-warranty service anywhere in Canada.
- Features and specifications on our full line of appliances.
- Referrals to local Jenn-Air® appliance dealers.
- Use and maintenance procedures.
- Accessory and repair parts sales.

### For further assistance:

If you need further assistance, you can write to Jenn-Air Canada with any questions or concerns at:

Customer eXperience Centre  
Jenn-Air Canada  
200 - 6750 Century Ave.  
Mississauga, Ontario L5N 0B7

Please include a daytime phone number in your correspondence.

---

## Accessories

### Affresh® Cooktop Cleaner

Order Part Number W10355051

### Cooktop Cleaning Pads

Order Part Number W10391473

### Recirculation Kit

(For recirculation installation only)  
Order Part Number W10807915

### Charcoal Filters

(for recirculation installation only)  
Order Part Number W10807916

### Y-Transition Ducting Kit

Order Part Number W11180669



# JENN-AIR® COOKING LIMITED WARRANTY

ATTACH YOUR RECEIPT HERE. PROOF OF PURCHASE IS REQUIRED TO OBTAIN WARRANTY SERVICE.

Please have the following information available when you call the Customer eXperience Center:

- Name, address and telephone number
- Model number and serial number
- A clear, detailed description of the problem
- Proof of purchase including dealer or retailer name and address

## IF YOU NEED SERVICE:

1. Before contacting us to arrange service, please determine whether your product requires repair. Some questions can be addressed without service. Please take a few minutes to review the Troubleshooting or Problem Solver section of the Use and Care Guide, or visit <https://jennair.custhelp.com>.
2. All warranty service is provided exclusively by our authorized Jenn-Air Service Providers. In the U.S. and Canada, direct all requests for warranty service to:

**Jenn-Air Customer eXperience Center**  
**1-800-JENNAIR (1-800-536-6247).**

If outside the 50 United States or Canada, contact your authorized Jenn-Air dealer to determine whether another warranty applies.

## FIVE YEAR LIMITED WARRANTY

### WHAT IS COVERED

#### TWO YEAR LIMITED WARRANTY (PARTS & LABOR)

For two years from the date of purchase, when this major appliance is installed, operated and maintained according to instructions attached to or furnished with the product, Jenn-Air brand of Whirlpool Corporation or Whirlpool Canada, LP (hereafter "Jenn-Air") will pay for factory specified replacement parts and repair labor to correct defects in materials or workmanship that existed when this major appliance was purchased or, at its sole discretion replace the product. In the event of product replacement, your appliance will be warranted for the remaining term of the original unit's warranty period.

#### THIRD THROUGH FIFTH YEAR LIMITED WARRANTY (CERTAIN COMPONENT PARTS ONLY - LABOR NOT INCLUDED)

In the third through fifth years from the date of original purchase, when this major appliance is installed, operated and maintained according to instructions attached to or furnished with the product, Jenn-Air will pay for factory specified parts for the following components to correct non-cosmetic defects in materials or workmanship in these parts that prevent function of this major appliance and that existed when this major appliance was purchased. This is a limited 5-year warranty on the below named parts only and does not include repair labor.

- Electric element
- Touch Pad and microprocessor
- Glass ceramic cooktop: if due to thermal breakage
- Electronic controls
- Magnetron tube
- Sealed gas burners

YOUR SOLE AND EXCLUSIVE REMEDY UNDER THIS LIMITED WARRANTY SHALL BE PRODUCT REPAIR AS PROVIDED HEREIN. Service must be provided by a Jenn-Air designated service company. This limited warranty is valid only in the United States or Canada and applies only when the major appliance is used in the country in which it was purchased. This limited warranty is effective from the date of original consumer purchase. Proof of original purchase date is required to obtain service under this limited warranty.

### WHAT IS NOT COVERED

1. Commercial, non-residential, multiple-family use, or use inconsistent with published user, operator or installation instructions.
2. In-home instruction on how to use your product.
3. Service to correct improper product maintenance or installation, installation not in accordance with electrical or plumbing codes or correction of household electrical or plumbing (i.e. house wiring, fuses or water inlet hoses).
4. Consumable parts (i.e. light bulbs, batteries, air or water filters, preservation solutions, etc.).
5. Defects or damage caused by the use of non-genuine Jenn-Air parts or accessories.
6. Conversion of products from natural gas or propane gas.
7. Damage from accident, misuse, abuse, fire, floods, acts of God or use with products not approved by Jenn-Air.
8. Repairs to parts or systems to correct product damage or defects caused by unauthorized service, alteration or modification of the appliance.
9. Cosmetic damage including scratches, dents, chips, and other damage to the appliance finishes unless such damage results from defects in materials and workmanship and is reported to Jenn-Air within 30 days.
10. Discoloration, rust or oxidation of surfaces resulting from caustic or corrosive environments including but not limited to high salt concentrations, high moisture or humidity or exposure to chemicals.
11. Food or medicine loss due to product failure.
12. Pick-up or delivery. This product is intended for in-home repair.
13. Travel or transportation expenses for service in remote locations where an authorized Jenn-Air servicer is not available.
14. Removal or reinstallation of inaccessible appliances or built-in fixtures (i.e. trim, decorative panels, flooring, cabinetry, islands, countertops, drywall, etc.) that interfere with servicing, removal or replacement of the product.
15. Service or parts for appliances with original model/serial numbers removed, altered or not easily determined.

**The cost of repair or replacement under these excluded circumstances shall be borne by the customer.**

### DISCLAIMER OF IMPLIED WARRANTIES

IMPLIED WARRANTIES, INCLUDING ANY IMPLIED WARRANTY OF MERCHANTABILITY OR IMPLIED WARRANTY OF FITNESS FOR A PARTICULAR PURPOSE, ARE LIMITED TO FIVE YEARS OR THE SHORTEST PERIOD ALLOWED BY LAW. Some states and provinces do not allow limitations on the duration of implied warranties of merchantability or fitness, so this limitation may not apply to you. This warranty gives you specific legal rights, and you also may have other rights that vary from state to state or province to province.

### DISCLAIMER OF REPRESENTATIONS OUTSIDE OF WARRANTY

Jenn-Air makes no representations about the quality, durability, or need for service or repair of this major appliance other than the representations contained in this warranty. If you want a longer or more comprehensive warranty than the limited warranty that comes with this major appliance, you should ask Jenn-Air or your retailer about buying an extended warranty.

### LIMITATION OF REMEDIES; EXCLUSION OF INCIDENTAL AND CONSEQUENTIAL DAMAGES

YOUR SOLE AND EXCLUSIVE REMEDY UNDER THIS LIMITED WARRANTY SHALL BE PRODUCT REPAIR AS PROVIDED HEREIN. JENN-AIR SHALL NOT BE LIABLE FOR INCIDENTAL OR CONSEQUENTIAL DAMAGES. Some states and provinces do not allow the exclusion or limitation of incidental or consequential damages, so these limitations and exclusions may not apply to you. This warranty gives you specific legal rights, and you also may have other rights that vary from state to state or province to province.



